

TWIN PARK - DEPENDANT

RR-ETP-20000

ETP - ELECTROMECHANICAL

CAR DATA

TYPE	H	LOWER	UPPER	CAR TYPE
RR-ETP-20000	3600	1800	1550	SEDAN + TB
	3900	2100	1550	SEDAN + SUV
	4200	2100	1850	TALL BOY + SUV
	4400	2100	2050	SUV + SUV

WIDTH: 2000 with Mirror
 WEIGHT: Max 2000 Kg.
 WHEEL LOAD: Max 500kg.

	WIDTH	MAIN (M)	M + A	M + 2A
		SW	SW1	SW2
USABLE PALLET	2000	2600	4900	7200
	2100	2700	5100	7500
	2200	2800	5300	7800

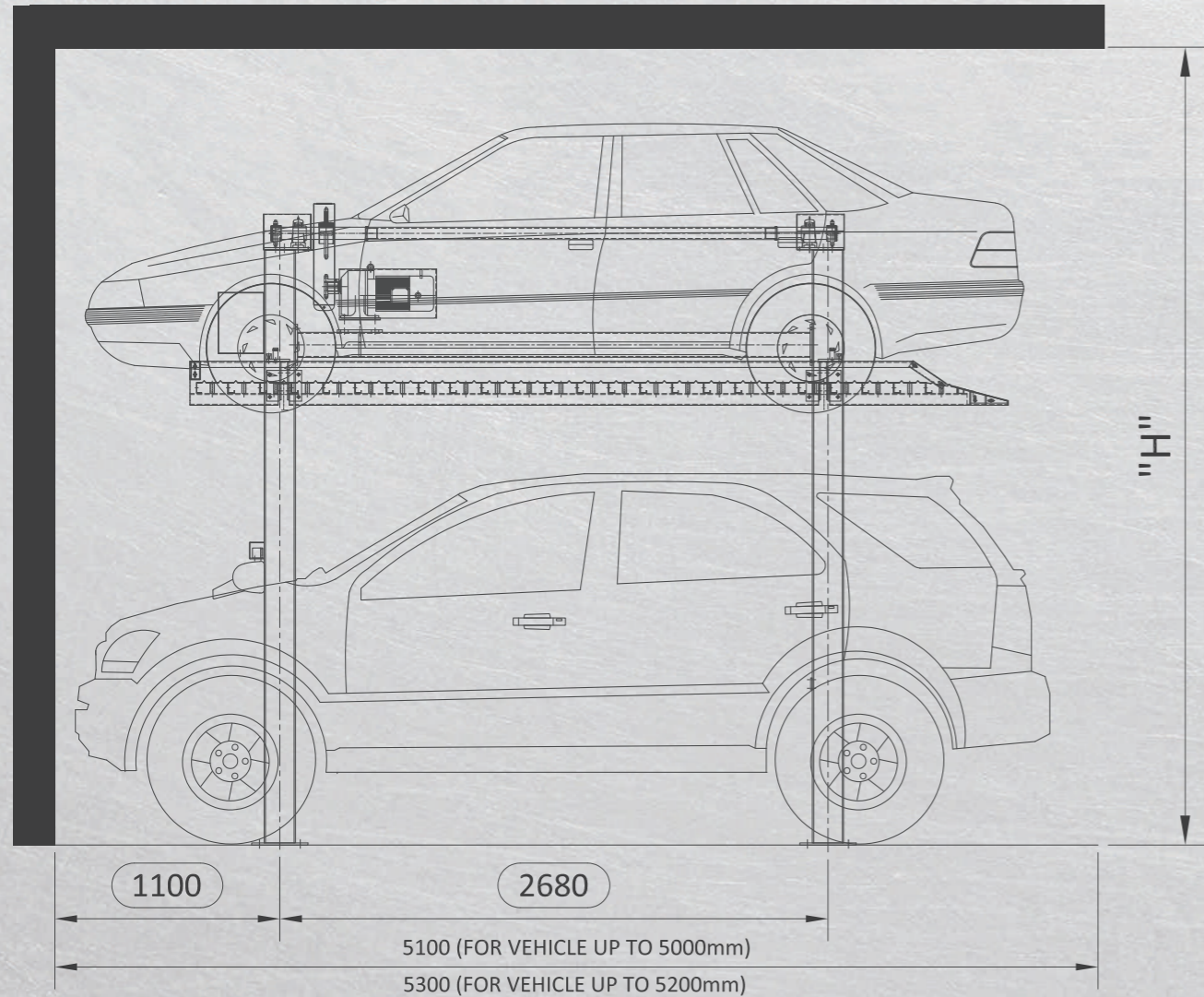

SHAFT LENGTH	CAR LENGTH	A
5100	5000	1100
5300	5200	1100

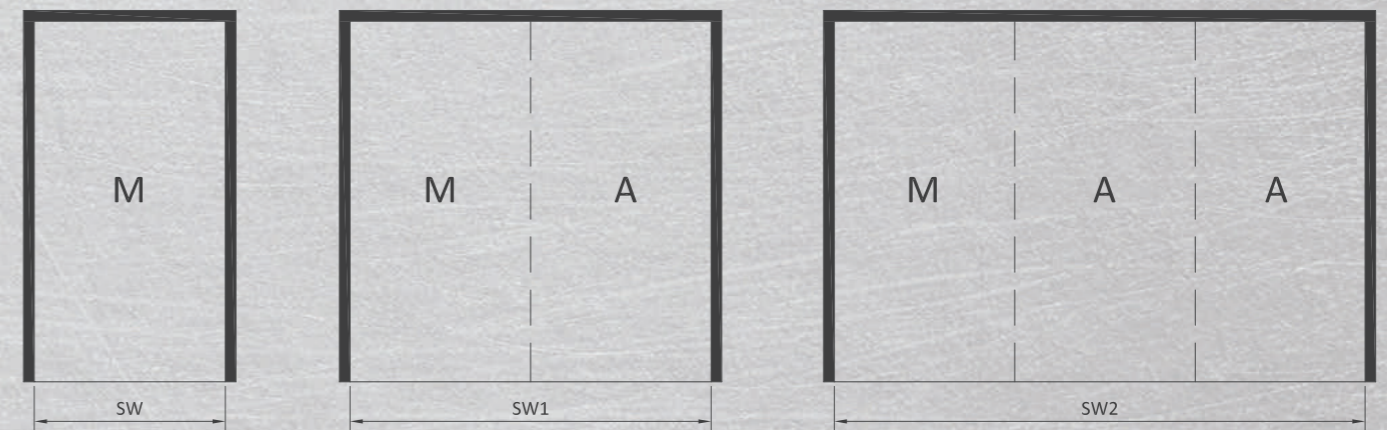
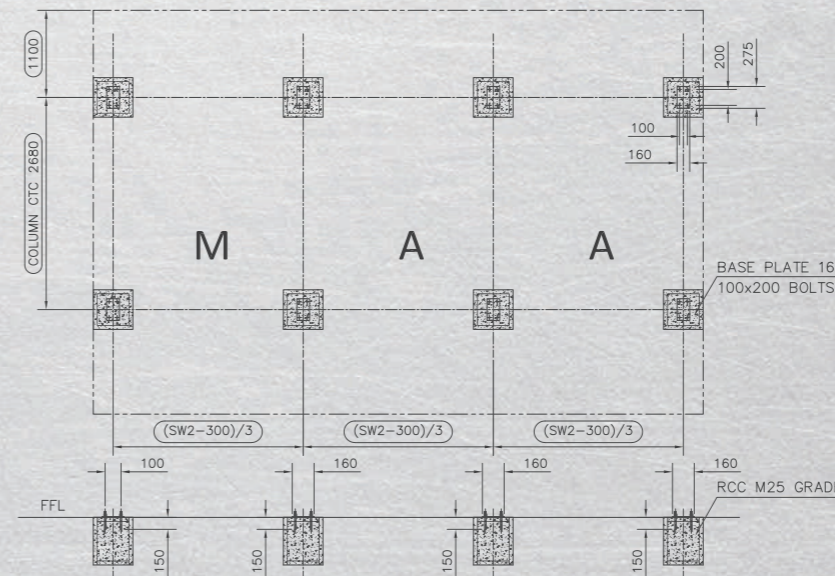
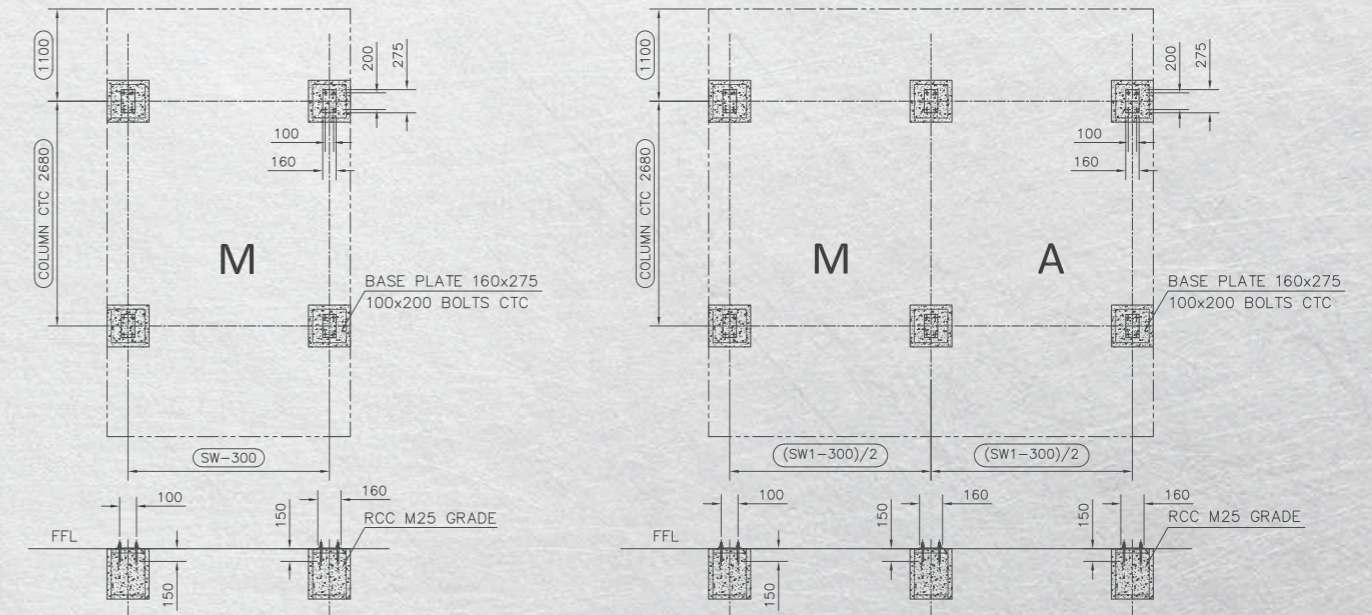

TWIN PARK - DEPENDANT

RR-HTP-20000

HTP - HYDRAULIC

CAR DATA

TYPE	H	LOWER (Y)	UPPER (X)	CAR TYPE
RR-HTP-20000	3250	1550	1500	SEDAN + SEDAN
	3400	1650	1550	HB + SEDAN
	3500	1750	1550	TB + SEDAN
	3600	1750	1650	TB + HB
	3700	1750	1750	TB + TB
	3600	1850	1550	TB + SEDAN
	3700	1950	1550	TB + SEDAN
	3800	2050	1550	SUV + SEDAN
	3900	2050	1650	SUV + HB
	4000	2050	1750	SUV + TB
	4100	2050	1850	SUV + TB
	4200	2050	1950	SUV + TB
	4300	2050	2050	SUV + SUV

WIDTH: 1900 with Mirror (For 2200 mm Pallet W)
 WEIGHT: Max 2000 Kg.
 WHEEL LOAD: Max 500kg.

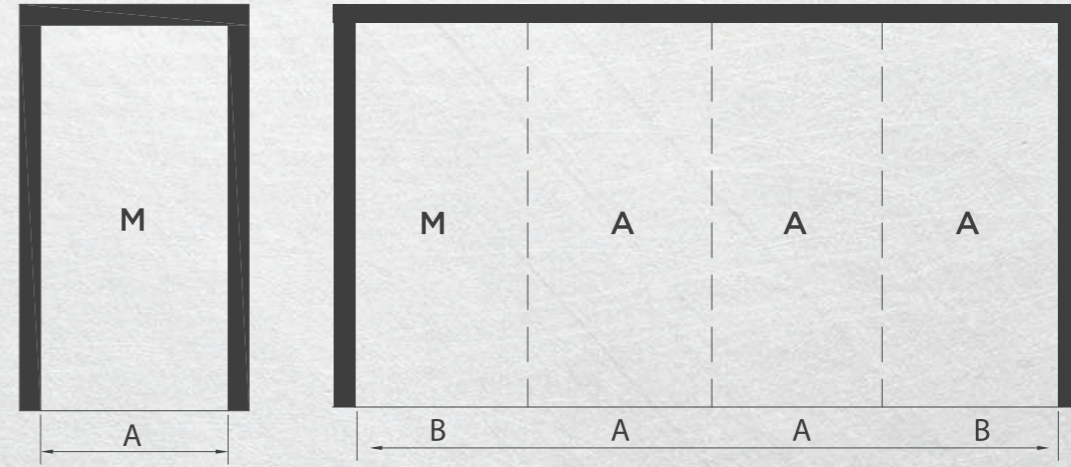
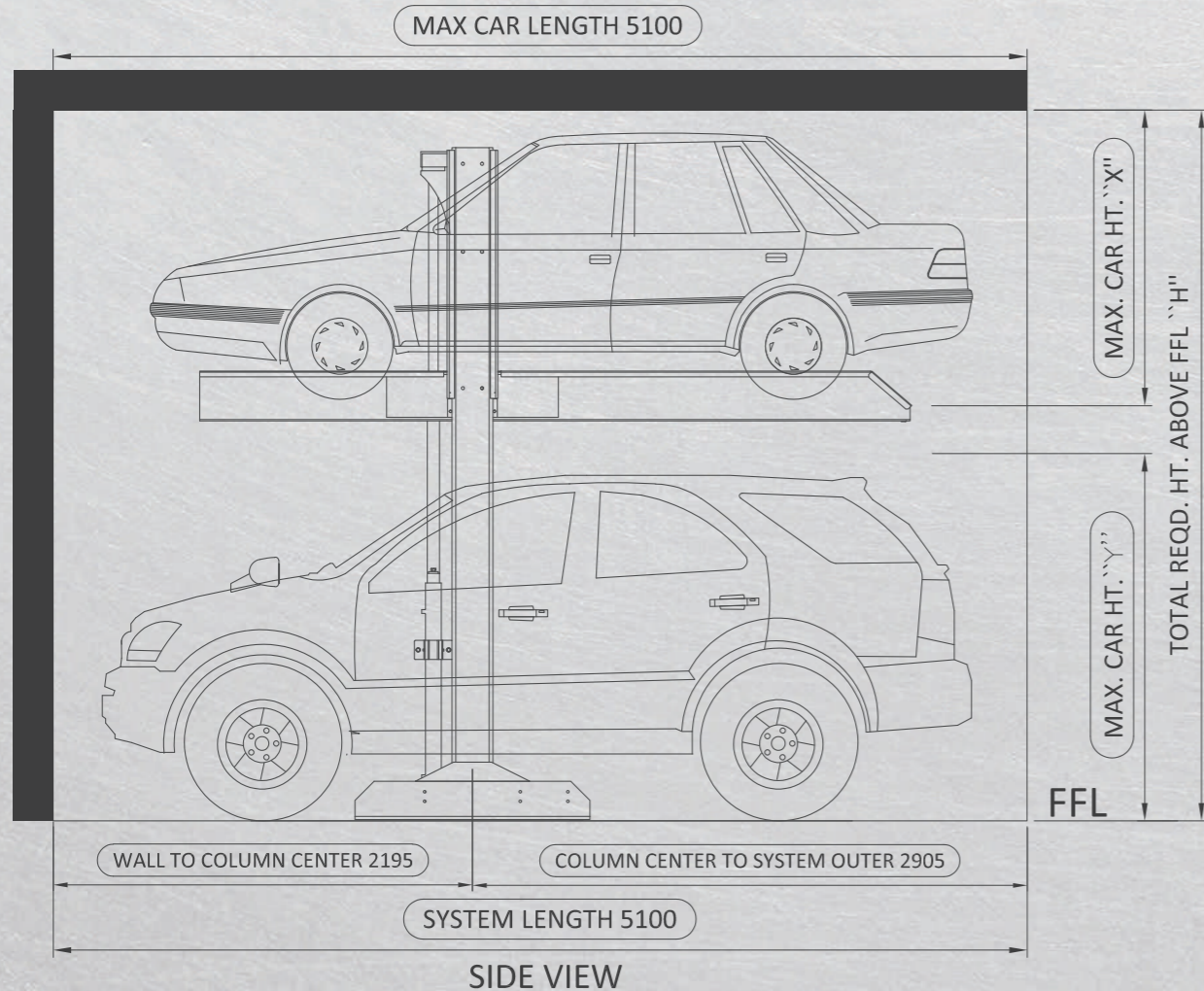

M WIDTH	WIDTH	MAIN (M)	USABLE PALLET WIDTH	A	B	M + A	M + 2A
USABLE PALLET		A				B+B	B+A+B
	2000	2350	2000	2331	2312	4624	6955
	2100	2450	2100	2431	2412	4824	7255
	2200	2550	2200	2531	2512	5024	7555
	2300	2650	2300	2631	2612	5224	7855
	2400	2750	2400	2731	2712	5424	8155

SHAFT LENGTH	CAR LENGTH
5100	5000
5300	5200

Load per platform max. 2000 kg (load per wheel max. 500 kg)

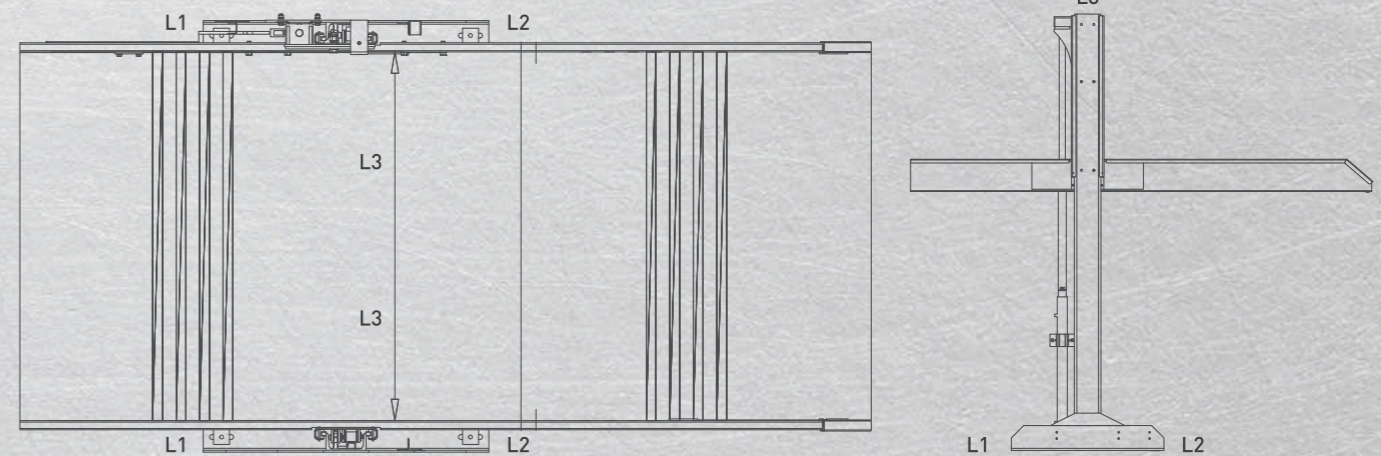

LOAD DETAILS FOR SINGLE SYSTEM	
L1	15Kn*
L2	7.5Kn
L3	3Kn

*All static load including car weight

- The system will be fixed on the anchor point's with heavy duty anchor fasteners to a depth of approx. 100 – 120 mm.
- Base thickness minimum 200 mm Concrete quality according to the static Requirements of the building, for fastening we require a concrete Grade of min. C20/ C25.
- Special foundations are required with asphalt floors or paving –stones.
- Support for system will be taken from RCC wall, Column or slab as per availability.